



MANUAL CALL POINT

TYPE FD3050

INSTRUCTION MANUAL 05-3050-09-16



GENERAL DESCRIPTION

The manual call point FD3050 is designed for indoor installation as a component of a Conventional Fire Alarm System. The unit is compatible with the requirements of the European Standard EN54-11; A1:2005. Unpacking of the manual call point is shown in the sequence of steps: Poz.1,2 4 and 3, Fig. 4 . The protective cover (pos. 2 fig. 4) is accessory to the Manual call point FD3050.

TECHNICAL DATA

Supply voltage	(10-30) VDC
Resistance load and Alarm threshold current.	Refer Fig.2
Electrical Installation	Through terminal for connecting wires with cross-section (0,5-1,5) mm ²
Degree of protection	IP 40
Operational temperature range	from minus 10°C to plus 55°C
Relative humidity resistance	(93±3)% at 40°C
Dimensions	98x96x51 mm
Weight of the manual call point	0.150 kg
Material	ABS

INSTALLATION

To install the manual call point, please refer the sequence pos. 4, 5, 6, 7, 8, 9, 10, and 11 of fig. 5:

Detailed wiring diagram is shown on fig.1

The manual call point is able to trigger dry contact, refer wiring diagram fig. 2.

Alarm threshold current in state of operation (Fire mode) is 60mA when operate with UniPOS conventional line.

If necessary to change the manual call point alarm threshold current, cut the additional bridges (fig.3).

TESTING

The manual call point is tested as a part of the Conventional Fire Alarm System or on service schedule.

1. Test procedure

1.1. Power supply the manual call point from the conventional fire detection line (10-30V).

1.2. Press the manual call point on the specific place till showing of the two yellow thumb of the actuating member fig 5, pos 5.

1.3. The manual call point is activated - in "Alarm mode".

2. Reset to duty mode:

To reset the manual call point to duty mode, please refer the sequence pos. 2, 4, 5, 6 and 7 of fig. 5

**The reset key must be rotate clockwise to retract two yellow thumb
of the actuating member fig 5, pos 5.**

SERVICE SCHEDULE

- | | |
|---|-----------|
| 1. Inspection for visible physical damage | - weekly |
| 2. Trigger on standard operation scenario | - monthly |

WARRANTY

The warranty period is 36 months from the date of purchase.

The manufacturer guarantees the normal operation of the unit providing that the requirements set herein have been observed.

The manufacturer does not bear warranty liabilities for damages caused through accidental mechanical damage, misuse, adaptation or modification after production. The manufacturer bears warranty liabilities for damages in the unit caused through manufacturer's fault only.

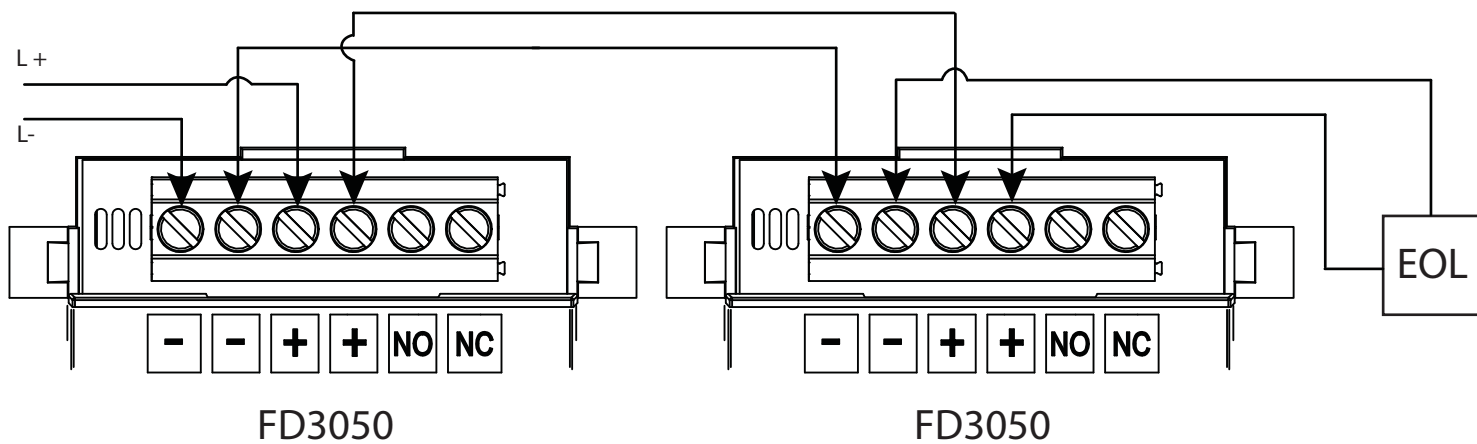

Фиг.1/ Fig.1

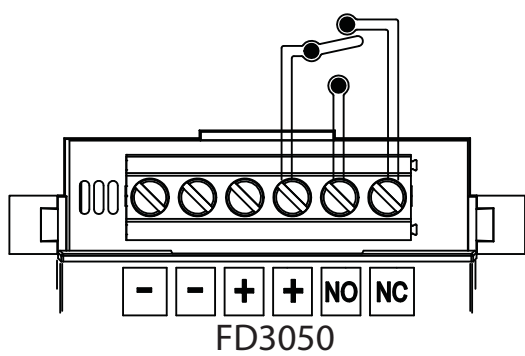

Фиг.2/ Fig.2

PCB layout	R, Ω
	400
	600
	1200

Фиг.3/ Fig.3

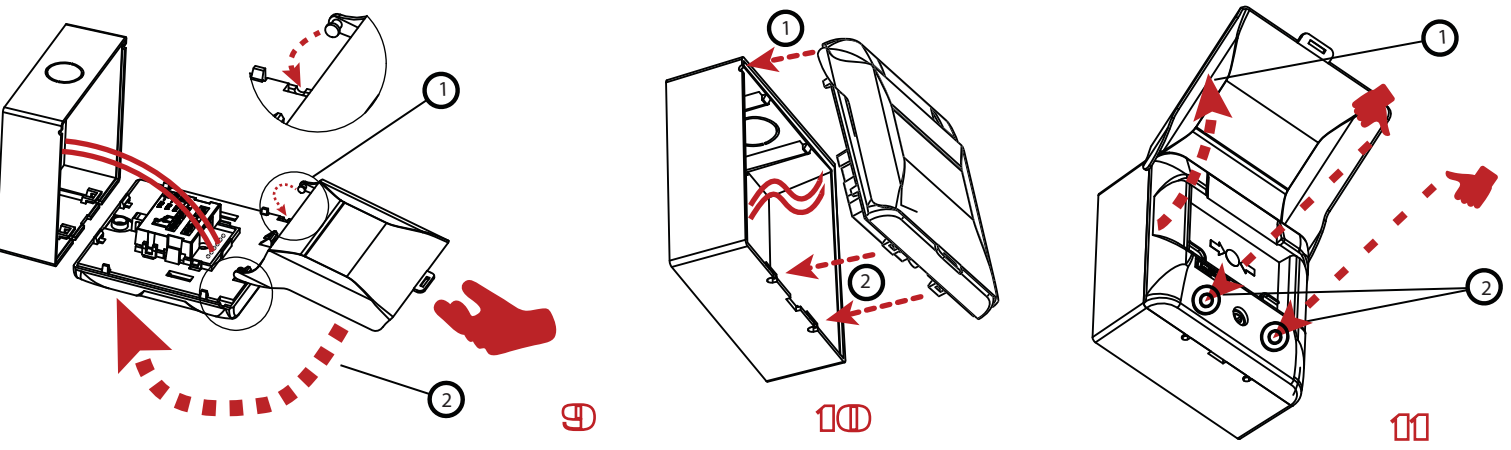
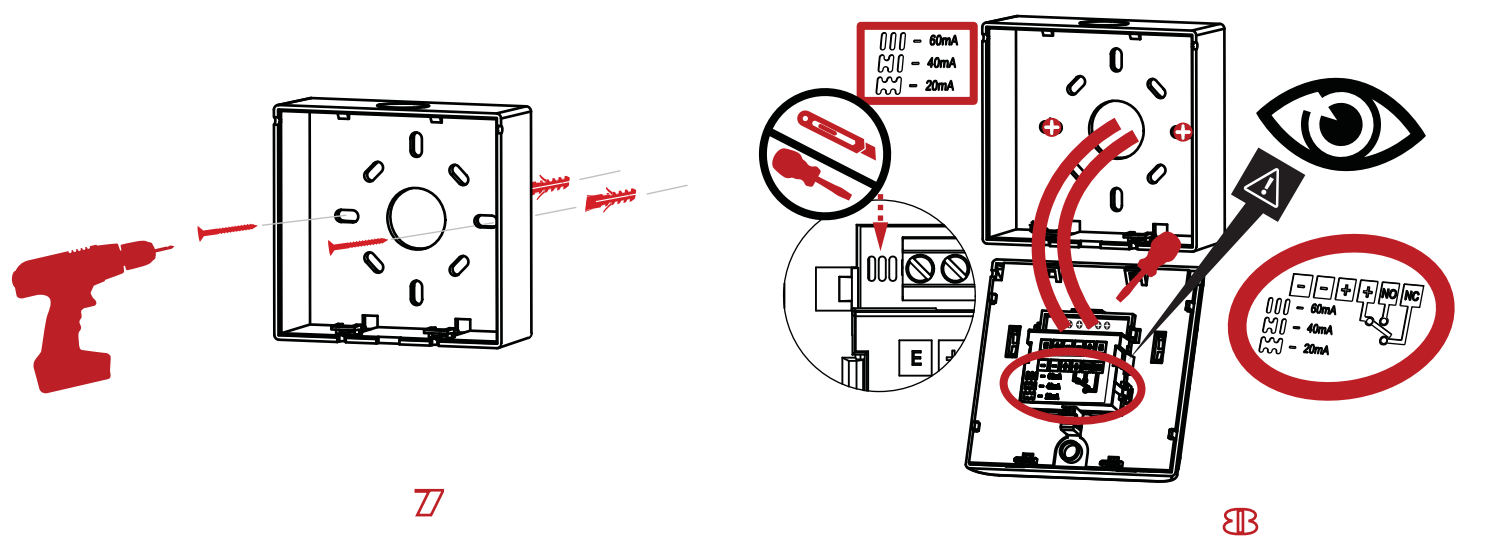
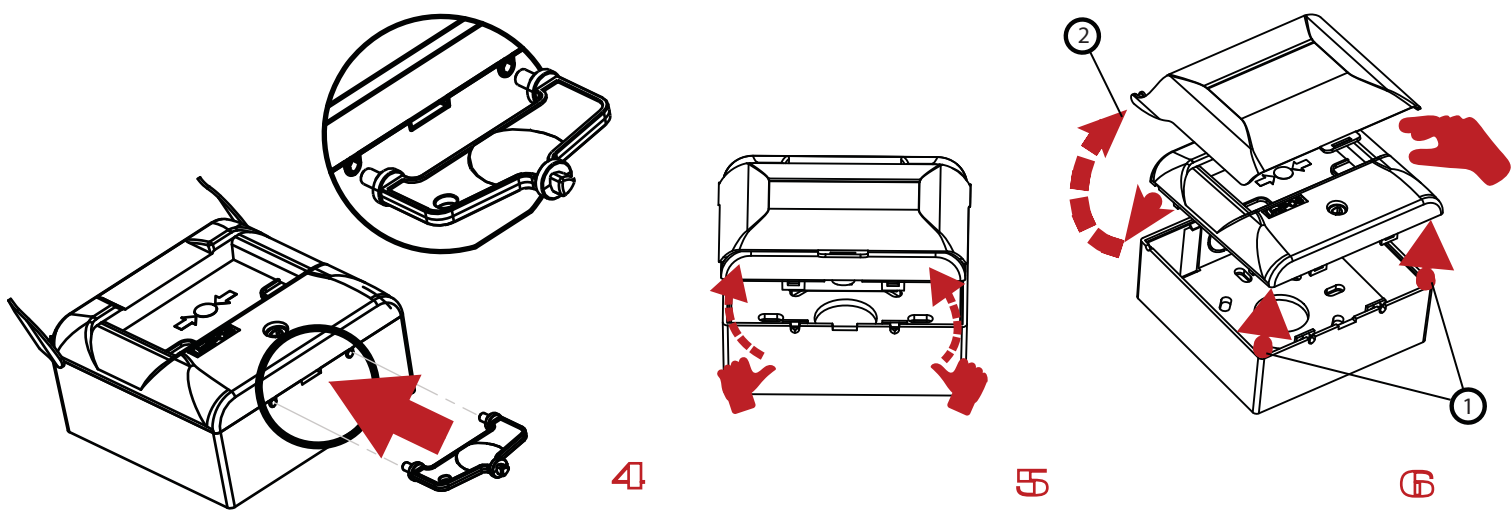
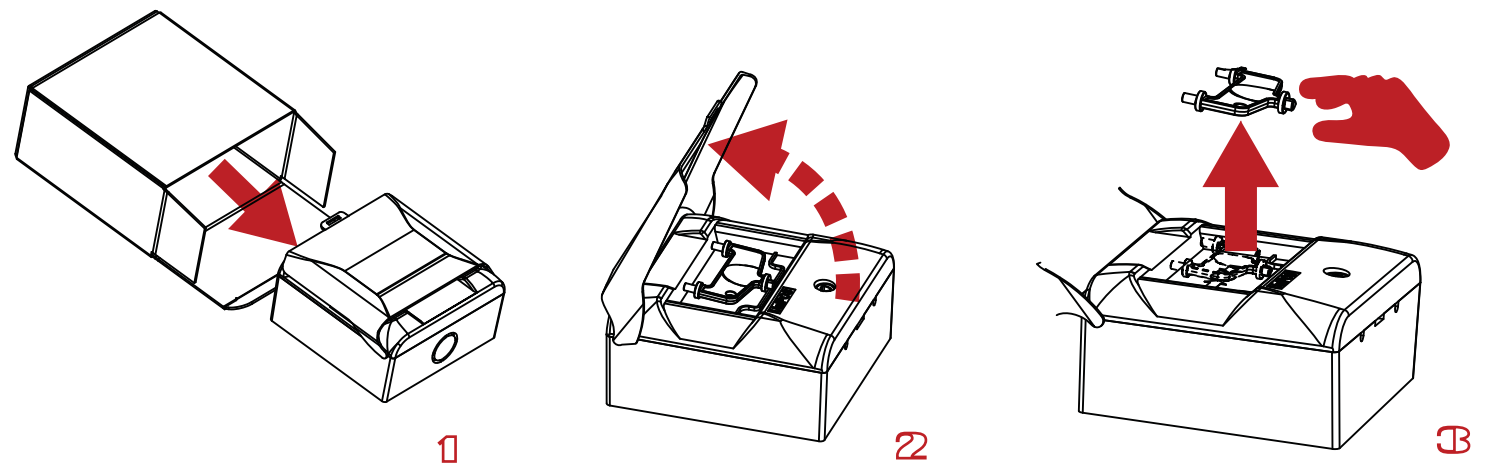

Фиг.4/ Fig.4

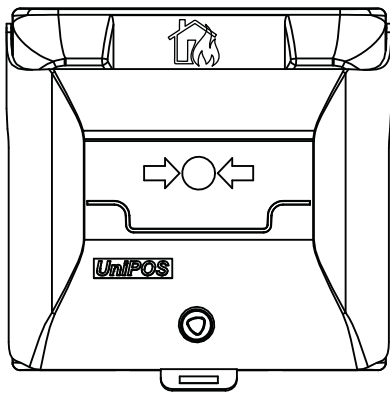

1

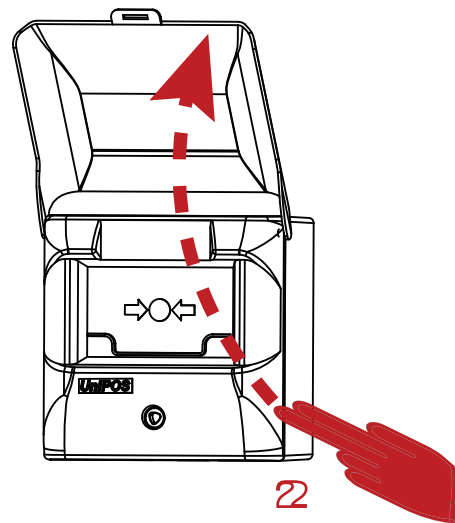

2

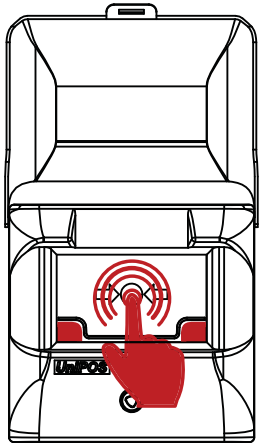

3

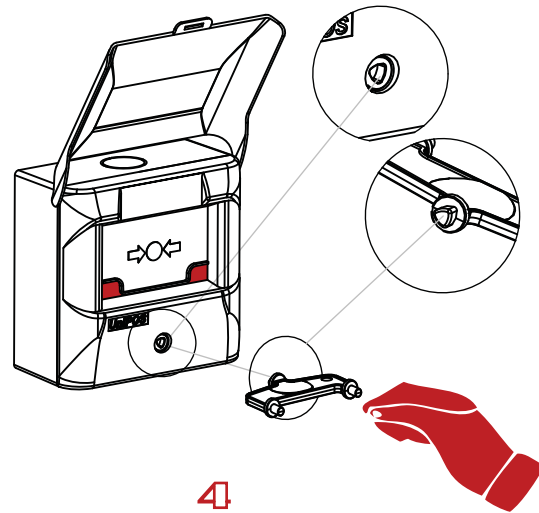
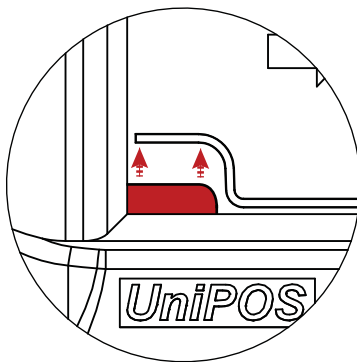

4

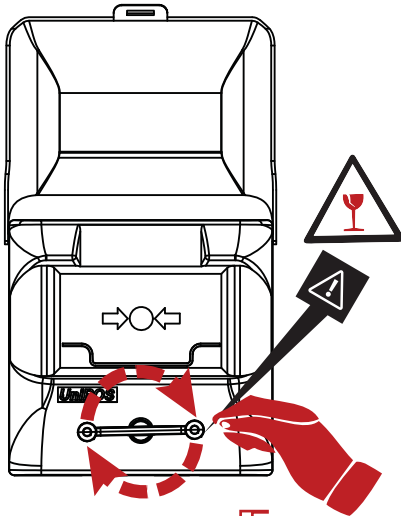

5

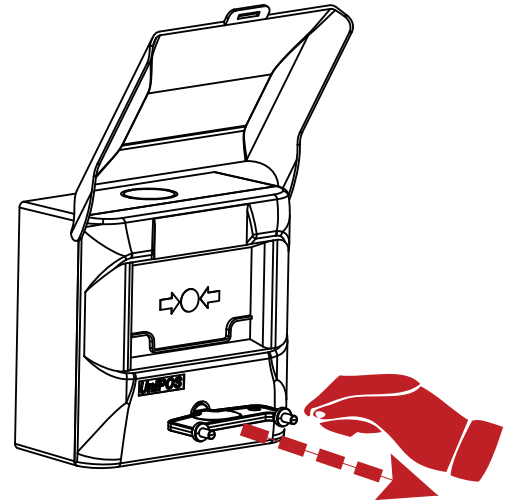
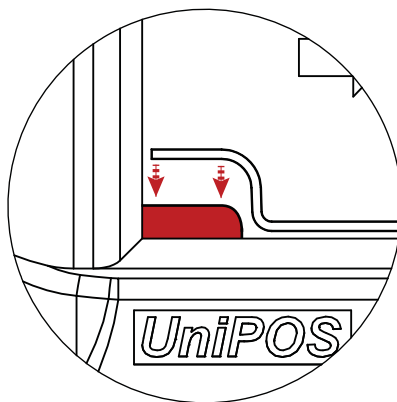

6

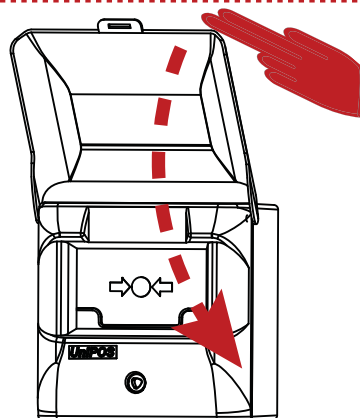

7

Фиг.5/ Fig.5