



VZ-195-2

Sistem automatizare usi glisante duble

Imagine



YLI Eternit Acces SRL
Str. Haiducului 3A
Cluj-Napoca, 400040
Webpage: www.yli.ro

VZ-195-2
Sistem automatizare usi glisante duble
Fisa Tehnica

Descriere

VZ-195-2 este un set de automatizare pentru usi glisante duble. Suporta o capacitate de incarcare de maxim 185kg pe fiecare usa. Sistemul de control inteligent suporta o gama larga de echipamente auxiliare iar capatul de cursa este stabilit in mod automat fara a utiliza alti senzori de pozitie.

Continutul pachetului

- VZ-195P-1: Unitatea de comanda
- VZ-195P-2: Motor
- VZ-195P-3: Set role (1 set = 2 role), pentru usi duble se dau 2 seturi
- VZ-195P-4: Set intinzator de curea, opritor capat de cursa, cablu alimentare
- VZ-195P-5: Curea trapezoidala dintata
- VZ-195P-6: Set elemente de capat
- VZ-195-SIN42: Sina montaj de 4200mm lungime

Echipamente optionale

- VZ-FC03: Tastatura de programare
- VZ-FC04: Telecomanda de programare
- VZ-FC06: LCD de programare
- VZ-FG01: Ghidaj
- VZ-FP02: Ghiajd pentru usi de sticla
- VZ-GC01: Suport prindere 180 mm
- VZ-GC02: Suport prindere 1000 mm
- VZ-IS01: Senzor infrarosu de prezenta
- VZ-IS02: Senzor combinat
- VZ-KP01: Controler de acces cu cheie
- VZ-KP02: Controler de acces cu cheie
- VZ-MS01-B: Senzor de miscare cu microunde
- VZ-MS01-S: Senzor de miscare cu microunde
- VZ-MS04-B: Senzor de miscare cu microunde
- VZ-MS04-S: Senzor de miscare cu microunde
- VZ-PB06: Buton wireless
- VZ-PT02: Fotocelula (protectie impotriva inchiderii accidentale)

Specificatii

- | | |
|--------------------------|----------------------|
| •Tensiune de alimentare: | 90~250Vac, 50Hz |
| •Sarcina maxime port: | 24V/300mA |
| •Motor: | 24Vcc, 100W, 2300RPM |
| •Greutate usi: | max. 2 x 180kg |
| •Dimensiune: | 4200 x 155 x 165 mm |
| •Dimensiune usa: | 2x450~1500 mm |
| •Viteza de deschidere: | 20~55 cm/s |
| •Viteza de inchidere: | 10~55 cm/s |
| •Temporizare: | 0~60 secunde |

Caracteristici

- | | |
|----------------------|----------------------------|
| •Unitate de comanda: | Funcție de autoinvatare |
| •Exterior: | Design modern |
| •Nivel de zgomot: | Scazut |
| •Montare: | Usoara si rapida |
| •Motor: | Fara perii, cuplu puternic |
| •Mecanism tragere: | Curea trapezoidala dintata |



YLI Eternit Acces SRL
Str. Haiducului 3A
Cluj-Napoca, 400040
Webpage: www.yli.ro

VZ-195-2
Sistem automatizare usi glisante duble
Fisa Tehnica

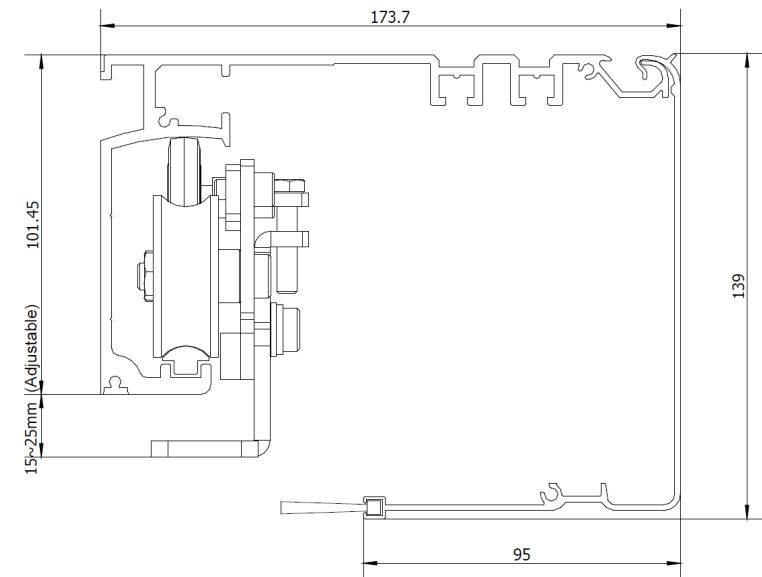
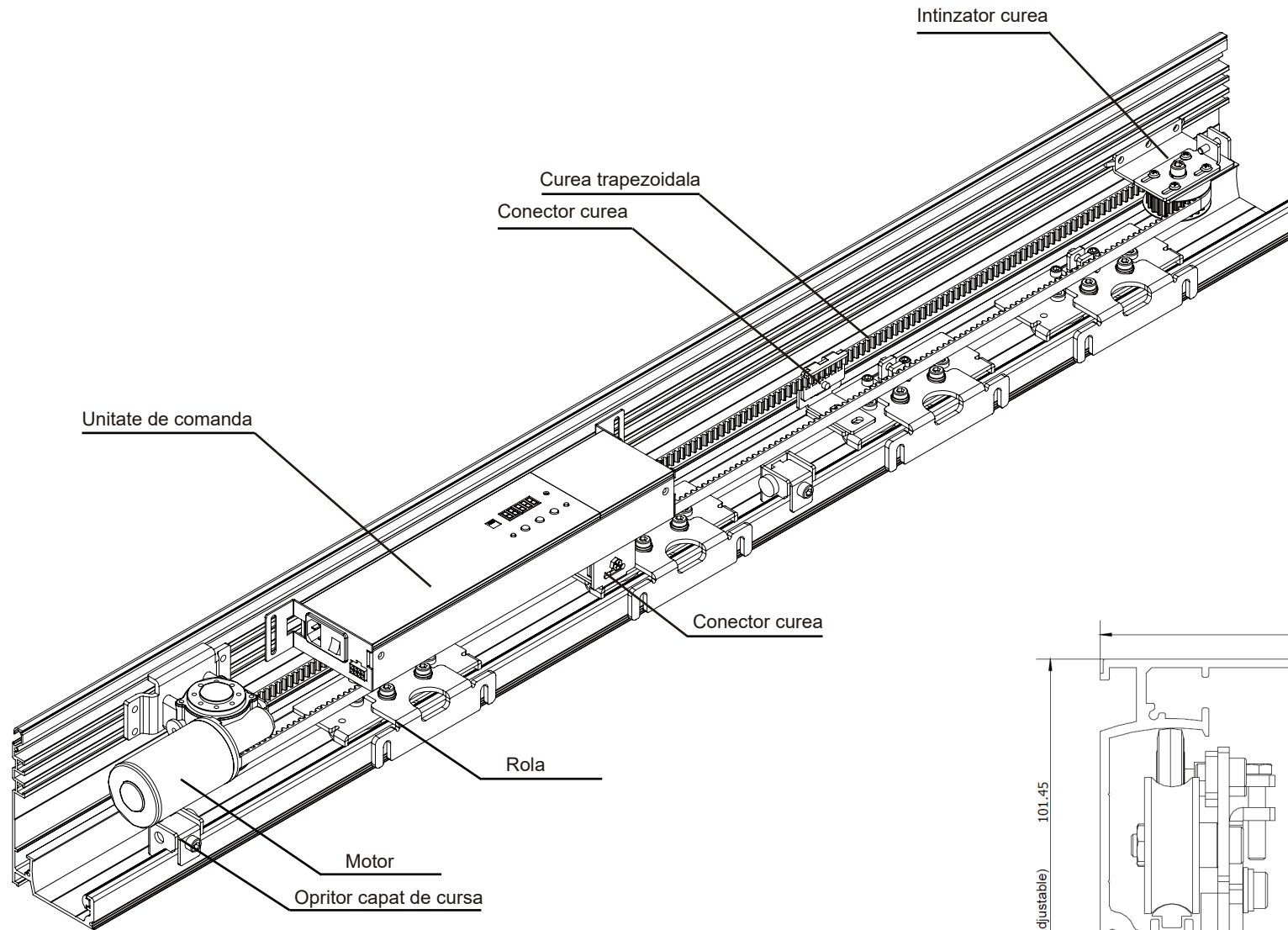

Vedere in sectiune



Unitate de comanda

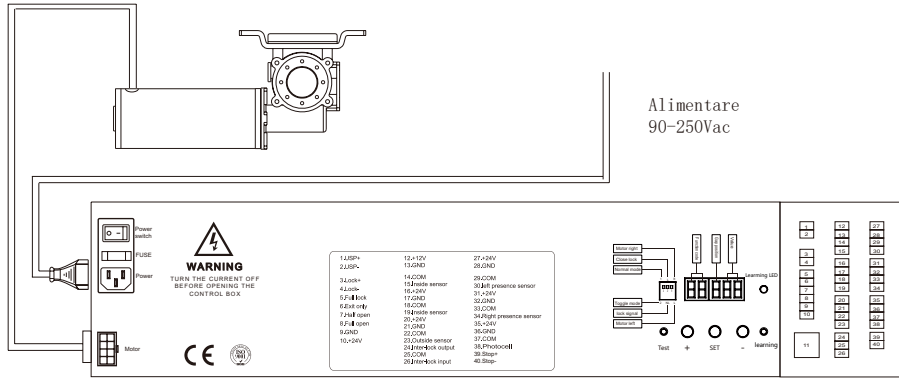

Interlock

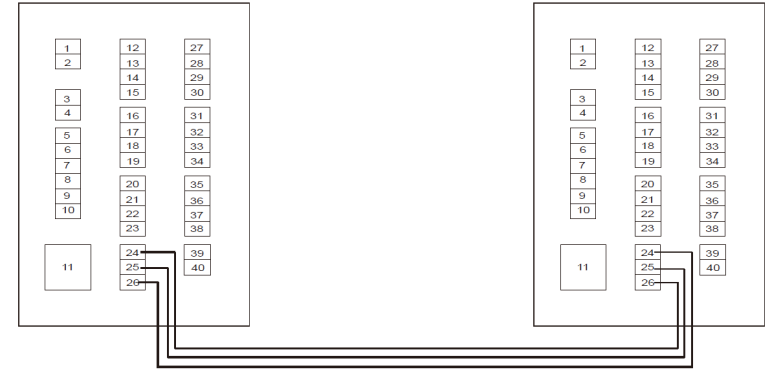

Conectare senzori comanda intrare/iesire

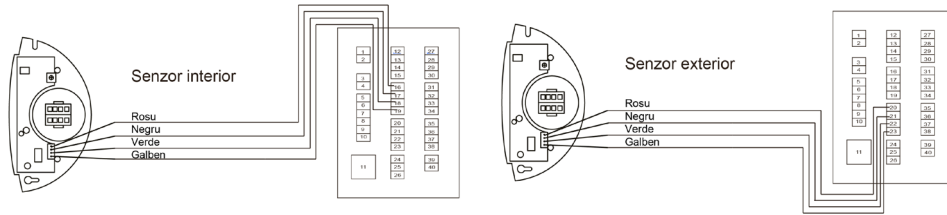

Conectare controler de acces (max. 12Vcc/2A)

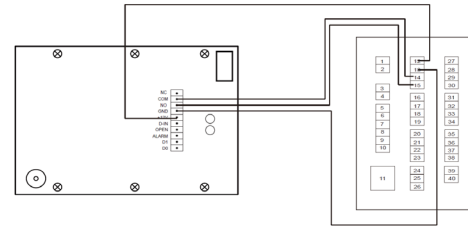

Conectare senzori prezenta

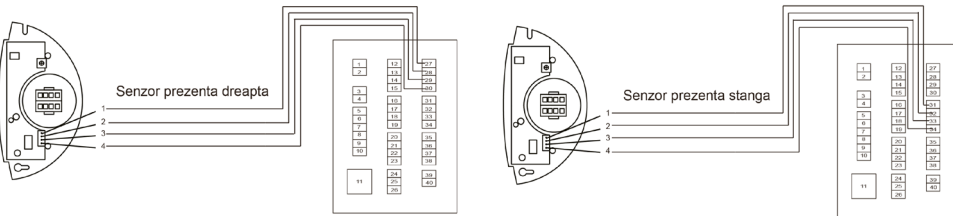

Conectare incuietoare electromagnetica

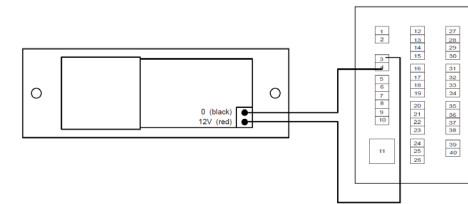

Conectare fotocelule VZ-PT02

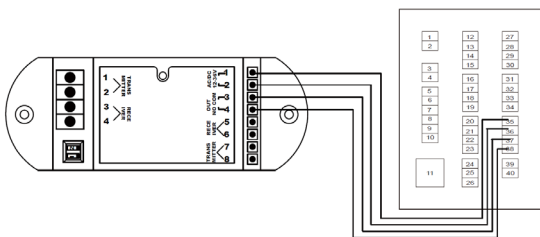

Conectare controler de acces cu taste VZ-FC03

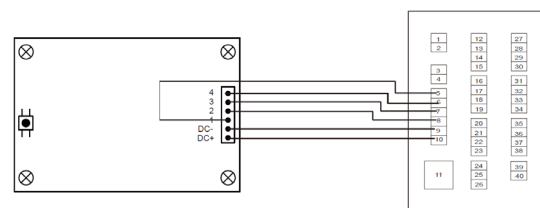

Observatii



EEE FAC OBIECTUL UNEI
COLECTARI SEPARATE

